

NOTE : This drawing contains proprietary and confidential information of Midland Industries...and shall not be copied, loaned or submitted to outside parties for examination without our prior consent.

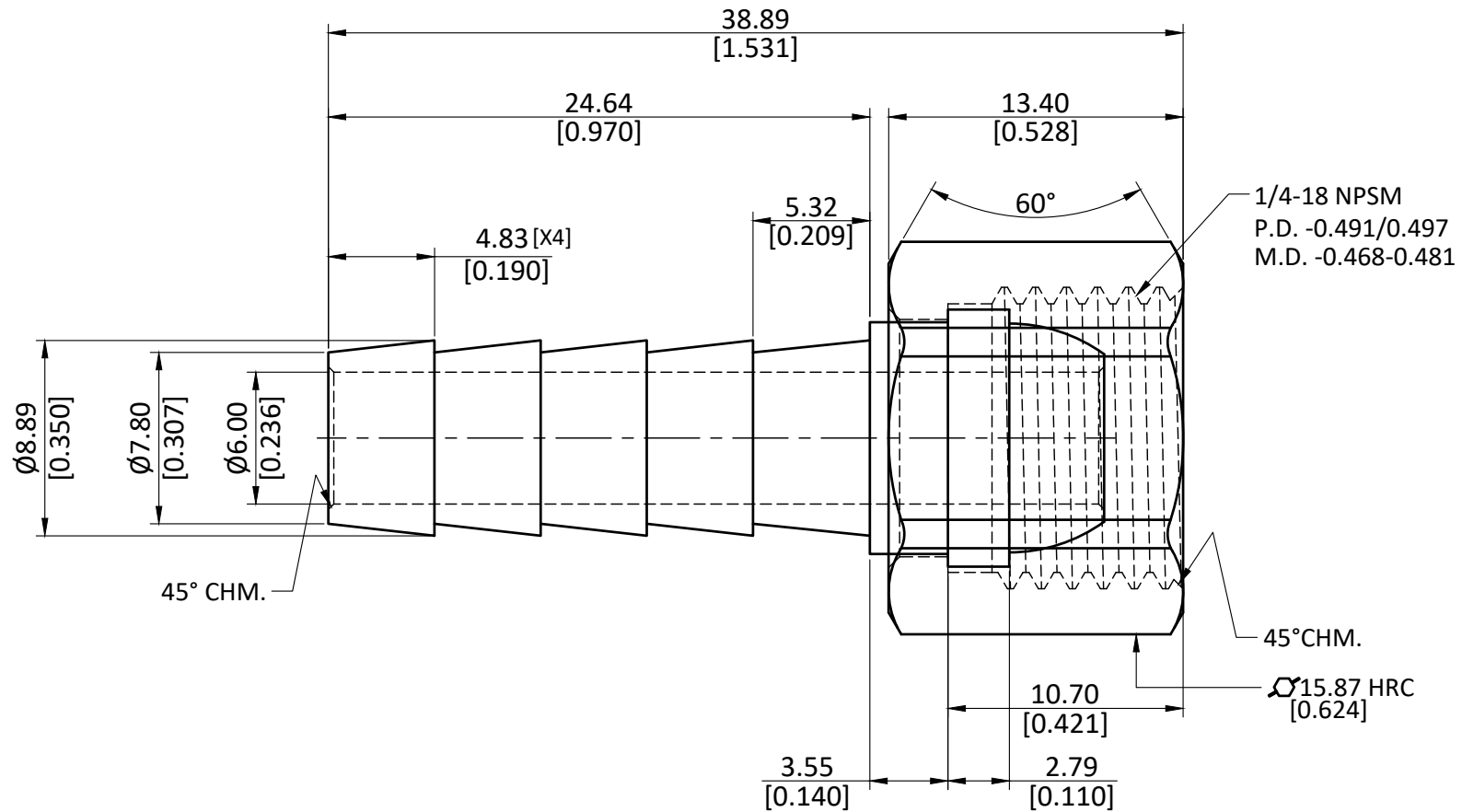

ALL DIMENSION ARE IN MM & INCH.

ROD SIZE: 11.70 Round

PROCESS: ASSEMBLY

ASSEMBLY: ASSEMBLE WITH NUT [ASSEMBLY WEIGHT(gm) : 21.35]

DRAWN

A.M.

11/01/2023

CHECKED

J.P.

11/01/2023

APPROVED

S.P.

11/01/2023

PART CODE:

32071

ITEM DESCRIPTION:

5/16 X 1/4 HB X BALL END SWIVEL

GRADE:

C3604

GENERAL TOLERANCE

MM ± 0.25
INCH ± 0.010
ANGLE $\pm 1^\circ$

WEIGHT (gm):

11.05

SCALE:
N.T.S.

REVISION:
01